

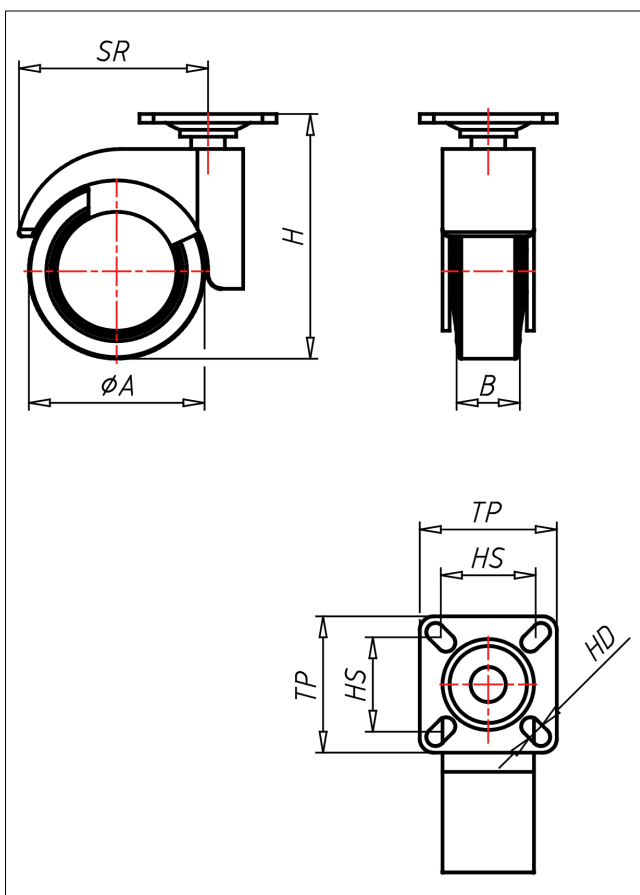

475 PT G

Swivel castor



475-G



Gehäuse: Zinkdruckguss - verchromt
Schwenklager mit kombiniertem
Gleit-Kugellager
Felge Polyamid 6
grauer Gummirifen - spurfrei
Radfeststeller glasfaserverstärkt
Radachse verschraubt

Technische Details

ORDERNO (Article-number)	475 PT 50 GK
WDAB (Wheel-Ø A x width B / mm)	50x18
LC (Load capacity / kg)	40
H (Overall height H / mm)	70
TP (Dimension of top plate / mm)	39x39
HS (Hole spacing / mm)	30x30/24x24
HD (Hole-Ø / mm)	5.2
SR (Swivel radius / mm)	51
WB (Wheel bearing)	Ball bearing